



# SteamOne

Water filtration system for steamer applications



SteamOne System: FO-06106-01  
\*FO-06106-02

20" Replacement Cartridge: MAXCL-20

Scale Stick Cartridge: SS-10  
\*SS-XL

## BENEFITS

Simple installation and maintenance

System reduces sediment, chlorine and scale adding years to equipment life

Long lasting cartridges

Hydroblend™ compound provides superior lime scale prevention and control for long term protection

The additives contained in HydroBlend™ are certified to ANSI/NSF Standard 60 at a maximum use level of 10 mg/L

## INSTALLATION TIPS

Mounting location must support full weight of filtration system

Allow enough clearance for easy cartridge replacement

Verify system is in place on the cold water side of the application

It is recommended to de-lime the equipment before installation, but is not required

## OPERATION TIPS

Replace 20" MAXCL-20 cartridge at least every 6 months

Inspect SS-10 cartridge at least every 6 months

Replace the SS-10 cartridge before the Hydroblend™ compound is completely used up

Pre-existing scale may be dislodged and settle to the bottom of a chamber and clog drain initially. Settled scale should be removed to assure satisfactory operation

## APPLICATION / SIZING

For medium to high volume steam applications

Low to medium volume applications include atmospheric and counter-top steamers, warming tables and rethermalizers

\*High volume applications include pressure steamers, stacked units and steamer / proofer combinations (require FO-06106-02 system)

## SPECIFICATIONS

Overall Dimensions:  
25 1/4" L x 5 3/4" D x 13 1/4" W

Inlet Connection: 3/4"

Outlet Connection: 3/4"

Service Flow Rate:  
3 GPM

Pressure Requirements:  
10-125 psi

Maximum water temperature  
at inlet:  
80° F

No electrical connection  
required

Shipping Weight: 14 lbs.

# SteamOne

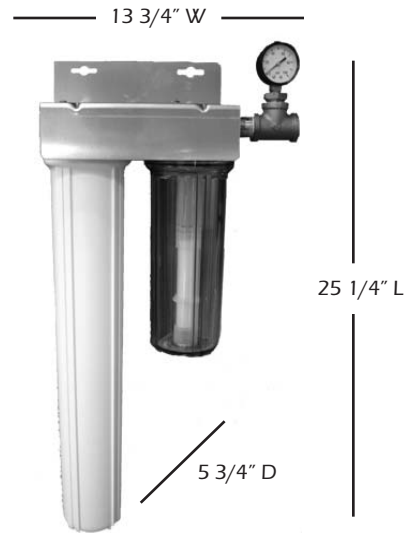

## WARRANTY

The warranty period commences from the date of purchase. Warranty is for material and workmanship, not filter cartridge life, for a period of one year. Replaceable elements ( filter cartridges ) are covered by a limited warranty against defects in material and workmanship for a period of one year after the date of purchase. FilterOne shall not be liable for damages or by failure of any parts due to normal wear and tear. FilterOne will not be liable for products that malfunction due to user neglect or unauthorized modification. Any malfunctioned part must be shipped prepaid to FilterOne. The warranty contained above does not extend to any goods not manufactured or assembled by FilterOne. See printed warranty for details. FilterOne will provide a copy of the warranty upon request.

## FILTERONE

1331 Upland Drive  
Building 6  
Houston, TX 77043  
Phone: 888.829.2781 Fax: 866.512.4057

## DISTRIBUTED BY: